

The malfunctioning medical machine

Application Note



Power Quality Case Study

Measuring tools: Fluke 43B Power Quality Analyzer, Fluke 87 True-rms DMM, Fluke 27 DMM

Operator: Electrical contractor

Features used: True-rms voltage, average voltage, voltage waveform

Problem description

This case history is a classic example of the importance of a systematic approach to solving a problem. It involves a contractor who works with several high-technology manufacturing plants.

The case began with an on-site visit to a building manager who was frustrated with his electrical system. According to the manager, nothing electrical in his building seemed to work properly and no one had been able to determine why or offer a solution. The manager went on to say that three of his electricians had quit and that he was now in real trouble.

The contractor asked many questions – trying to get a more detailed picture of the problem. This effort proved fruitless, so the contractor asked to be taken to that part of the building where the problems were the worst. He was following the axiom, “When in doubt, start at the victim load.”

In a far corner, a large medical machine was going through a critical test procedure. The machine was equipped with a large display screen, a keyboard and a control panel with several

cables and hoses leading to other pieces of equipment. The operator display screen showed the test procedure was in progress.

Next to the machine was a workbench set up for circuit board repair. The workbench had a soldering iron, a lighted magnifying lens and a fan. The workbench power strip plugged into the same receptacle as the large medical machine. As the contractor watched, the person at the workbench reached over and turned on the fan. At that moment, the operator display screen momentarily went blank and then came back on with the words “Program Reset” displayed in large letters.

Measurements

The contractor measured the voltage at the receptacle feeding both loads. His Fluke 87 true-rms DMM measured 115 V. The building manager repeated the measurement with his Fluke 27 average-responding DMM, which displayed 118 V. Why did the true-rms unit read lower?

True-rms instruments will give correct, but lower readings than average-responding instruments on square waves or waveforms that look like square

waves. The contractor connected his Fluke 43B and displayed the voltage waveform. The display showed that the waveform (simulated in Fig. 1) was severely clipped at the top – making it more like a square wave than a sine wave. The peak value measured only 135 V, rather than the expected 162 V.

The contractor then drew a one-line diagram of the system. The one-line showed that the transformer supplying the test area was at the opposite end of the building – almost 500 feet away (see Fig. 2). The majority of the loads on that transformer were non-linear, and they were drawing high peak currents at the peak of the voltage. The combination of high peak currents and high impedance of the long run combined to produce severe voltage clipping at the end of the circuit – right where the test area was.

Theory and analysis

Since the medical machine’s internal circuits operated on low voltage dc, the internal power supply would have a diode/capacitor input circuit that required a certain minimum peak voltage for proper operation. The nameplate on the medical machine showed the machine needed a supply

voltage between 100 and 135 V rms ac. The engineers who designed the machine and specified the nameplate assumed the supply voltage would be a sine wave, so the minimum peak would be 141 V peak (100 x 1.41). Since the measured value of the peak input voltage was only 135 V, the machine was running on a peak voltage that was already 6 V below the absolute minimum required. When the fan was turned on, the surge current drawn by the fan motor further reduced the voltage to a point where the power supply of the machine went out of regulation. This is what caused the machine to reset.

Solution

The problem of voltage peak clipping (flat-topping) is common in high-tech buildings. Many of the buildings now in use were not designed to handle the vast array of computers and non-linear loads so typical today.

In this case, extensive rewiring would be necessary to reduce the voltage drop between the transformer and the load. An alternative would be to move the most sensitive loads closer to the transformer.

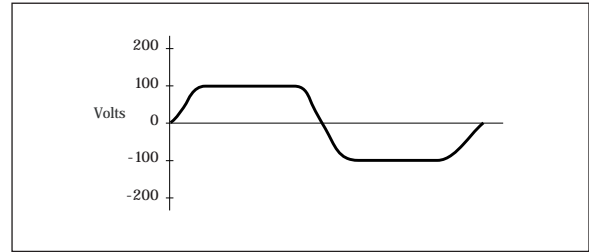

Fig. 1 Waveform of voltage supplying the medical machine (simulated)

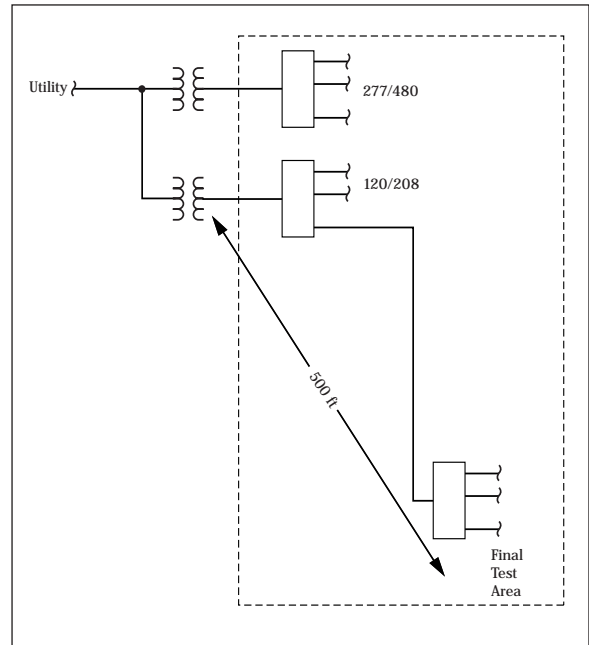

Fig. 2 Partial one-line diagram of the high-tech manufacturing plant

Fluke. Keeping your world up and running.

Fluke Corporation
PO Box 9090, Everett, WA USA 98206

Fluke Europe B.V.
PO Box 1186, 5602 BD
Eindhoven, The Netherlands

For more information call:
In the U.S.A. (800) 443-5853 or
Fax (425) 446-5116
In Europe/M-East/Africa (31 40) 2 675 200 or
Fax (31 40) 2 675 222
In Canada (800)-36-FLUKE or
Fax (905) 890-6866
From other countries +1 (425) 446-5500 or
Fax +1 (425) 446-5116
Web access: <http://www.fluke.com/>