

Finding a Power Quality needle

In a 30-mile haystack

Application Note



Power
Quality
Case
Study

Measuring tools: Fluke-RPM Recorder, ScopeMeter®, 41B Power Harmonic Meter

Operator: Bill McConnell, Var+Technologies and Vaughn DeCrausaz, Starboard Electric

Inspections: Power quality/harmonics logging at site, voltage distortion at multiple feeder lines



Photo by Don Svela

At the end of April 2005, Crystal Mountain Resort in Washington suffered catastrophic failure of two power filters associated with their chair lifts. The ski resort had just closed down for the season. Maintenance personnel were doing the end of the season maintenance and cleanup when they smelled the overheated reactors on the power filters. Crystal Mountain has four Var+Controls harmonic power filters located in the lift houses of their highest horsepower chair lifts. All of the filter units are programmed with two fixed steps to adjust to loading

and power conditions to absorb harmonic distortion, and the rest of the steps automatically turn on to obtain unity power factor for the greatest electrical efficiency when the lifts are in operation.

Crystal Mountain's electrical personnel measured the harmonic current in the power filters to determine the damage to the units. With the help of Bill McConnell of Var+Technologies, the team found that only the C-phase reactors in two of the power filters were damaged. They replaced those reactors and continued investigating the

cause of the failure throughout the summer. The filters were louder than usual but seemed to work.

At the start of the 2005 – 2006 ski season, the electrical maintenance personnel noted that, as more chair lifts were brought on line, the more overloaded the power filters became. They turned the filters off in an attempt to save the equipment and decrease the noise and smell in the lift houses. With the power filters off line, the lift dc drives were noisy, pumping systems on the mountain malfunctioned, variable frequency drives on

conveyors tripped off-line and data capture credit card systems failed. At that point, the team called Bill McConnell of Var+Technologies and Vaughn DeCrausaz of Starboard Electric to help troubleshoot the ski area's overall power system. Given the approaching Thanksgiving and Christmas holidays, finding a solution was of paramount importance.

On the way up to the ski area, DeCrausaz took a measurement with a Fluke 41B power meter at an outside receptacle of a convenience store in Greenwater. Greenwater is a bedroom community on the main power line feed from Enumclaw to Crystal Mountain. The voltage distortion was huge at 14 % shown below.

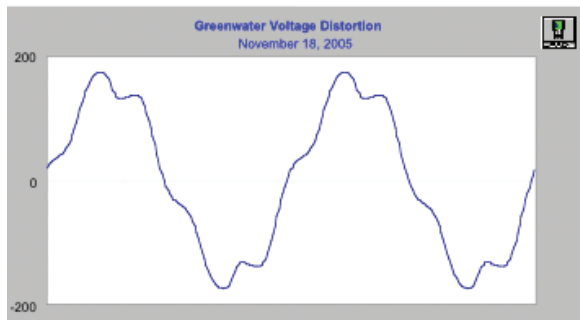

Greenwater convenience store 120 vac receptacle. All lifts at Crystal Mountain running. Filters off.

When first on-site, DeCrausaz and McConnell made an attempt to measure the voltage and current of the problem power filters with the lifts running, it turned out this was impossible due to the possibility of damaging the filter. The filter would have to absorb the entire harmonic current of the utility system plus the harmonic current generated by the dc drive of the lift. Note below the voltage waveform at Lift 11 with all the lifts running and NO filters on line.

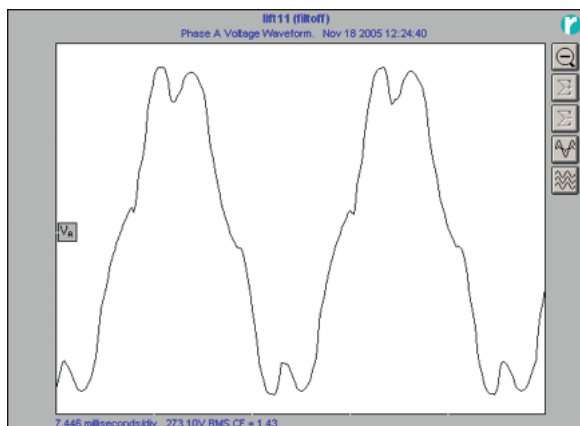

Lift 11 with all lifts running and no filters on line.

With all of the lifts running Saturday, DeCrausaz used a Fluke 199 Scopemeter® to check the Lift 11 dc drive armature SCR (Silicon Controlled Rectifier) pulses. The dc pulses to the motor were very erratic, varying in duration and amplitude. This was caused by the distorted voltage waveform affecting the dc motor field magnetism. With the collapse of the voltage waveform due to the armature SCR firing, voltage and current were decreased to the fields. The erratic firing of the SCR's caused the motor to try to run faster, lowered its torque, increased its current draw and also pulled power away from its field windings. In effect, the dc motor tried to run faster, with less torque (higher armature current) and with decreased fields.

The team consulted the local utility company to verify whether any changes in their system had occurred at the end of April. Were any new underground lines installed? Had any capacitor bank been installed or modified? Had any large loads been installed or removed?

Finally, after the ski area had been shut down for the evening, the techs were able to turn a power filter on without damaging it. They measured harmonics currents with a Fluke 3 phase RPM Power Recorder at 5 pm at the power filter of Lifts 10 and 11. The table below shows the current at the 5th harmonic (300 Hz).

Lift	Phase A (amps)	Phase B (amps)	Phase C (amps)	Imbalance Ph A-C
10	98.2	118.7	150.4	53.2 %
11	109.6	122.6	160.1	46.1 %
Average	103.9	120.65	155.25	49.4 %

Utility 5th (300) Hz Harmonic Current

Not only was the distortion abnormally high, but it was also very different between phases. The imbalance of 53 % pointed to a significant physical difference between the phases.

At night with no lifts running, the voltage distortion on the mountain was 6.1 % Total Harmonic Distortion (THD). The Institute of Electrical and Electronic Engineers (IEEE) 519-1992 Recommended Practices and Requirements for Harmonic Control in Electrical Power Systems lists 5 % THD as an upper limit. This "no load" distortion on the utility grid indicated a resonance either on the utility side at Crystal Mountain. The resonance or amplification at the 5th harmonic could be caused by high voltage capacitor banks lowering the resonant frequency of the power system or high voltage underground distribution lines coupling current to ground.

DeCrausaz and McConnell made several measurements along the power line coming from Enumclaw: the first at the supply end of the utility grid, the second at the town of Greenwater approximately 20 miles towards Crystal and the third at Crystal. They made the first measurements at a decommissioned sawmill five miles outside of Enumclaw fed by the 57 kv utility line that ultimately feeds Crystal. The voltage distortion at the sawmill was only 1.9% THD on the 480 v secondary, indicating that the utility feed to that point was good. DeCrausaz and McConnell took more measurements in the town of Greenwater, 20 miles closer to the ski area. On the side of the Greenwater convenience store, the distortion was 14 % with the lifts running and 6 % with the lifts off. Greenwater is fed from the 57 kv line transformed down to 12 kv from the local area. Crystal is further fed from this 12 kv line in Greenwater through a transformer to 34 kv. After passing through Greenwater the voltage is stepped up for the remaining distance to the mountain, along underground and overhead lines. The utility had a backup 2000 kw generator just off Crystal's property at 4160 volts transformed to 12 kv to match the 34 kv delivery voltage that is then transformed to 12 kv for distribution around the ski area. Crystal is primarily metered on this 12 kv line.

The utility felt that the problems were caused by some of the old 12 kv underground line located on the ski area. So, the team tested this theory by starting the mountain's 2000 kw backup generator at night with no lifts running and monitoring the voltage and current at one of the power filters. With the generator on in parallel (co-generating) with the utility, the 5th harmonic current to the power filter reduced to 60 amps, 72 amps and 88 amps, on phases A, B and C respectively. With the utility removed from the circuit, the 5th harmonic current was further reduced and balanced to 25 amps, 22 amps and 24 amps. This test proved the problem was on the utility system between Greenwater and the backup generator and not on Crystal's property.

After further investigation, a 900 kvar-capacitor bank was located on a pole near the Greenwater substation on the 12 kv line servicing the town. The capacitors had been switched online at the end of April for a still undetermined reason. During the summer the C-phase fuse had blown several times and been replaced. The C-phase fuse was out and hanging down when the capacitor bank was located. At that point, the utility removed the remaining two fuses and said it planned to remove the capacitor bank from the pole so that it couldn't be inadvertently energized.

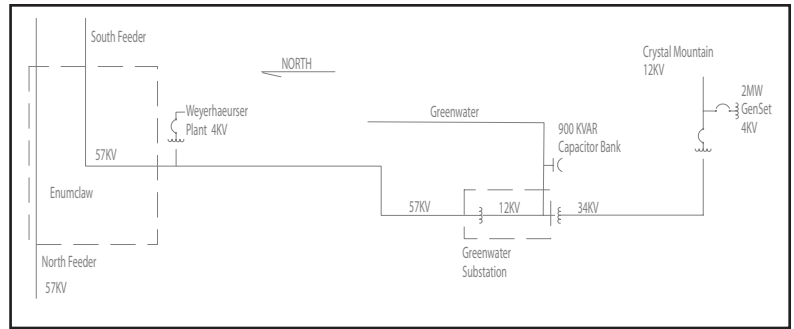

Later at the ski area, the following voltage waveform was recorded at Lift 11 with the mountain shutdown for the evening. Note the amount of distortion still on the utility system.

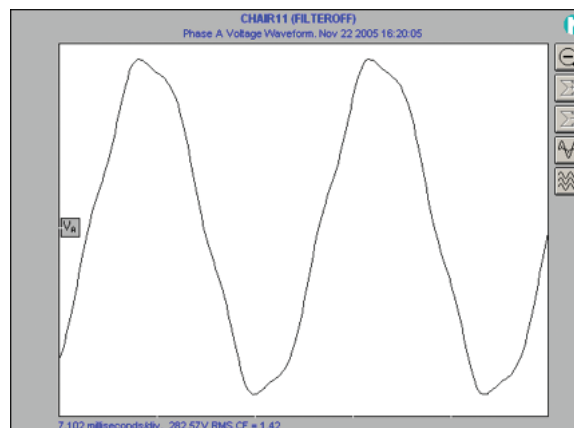

Lift 11 off. Filter off. All other lifts off. Utility caps off.

That evening at the ski area, all the power filters were put on-line and measurements taken to prove their health. The voltage distortion at the area was reduced to 3.1 % THD. The next day, technicians turned on all of the lifts with all four filters and all of the pumping stations and conveyors online. The voltage waveform below is at Lift 11 with all the lifts and filters on line.

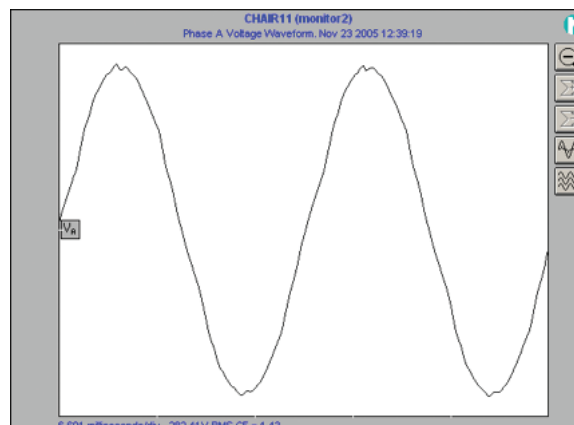

Lift 11 on, filter-3 steps. Lift 10 on, filter-3 steps. Lift 9 on, filter-3 steps. Lift 3 on, filter-2 steps. All other lifts running.

Lessons learned from this adventure:

- Have a good working relationship with your utility company. Without their help this problem would not have been isolated, located and solved.
- Have good electrical drawings of your facility and surrounding area as far back toward the source as possible. Visually check and update the documentation periodically.
- Pay particular attention to the utility’s equipment as far back as 50 miles from your facility. Capacitor banks and voltage regulators are sure signs of past anomalies. Note step down and buck up transformer combinations.
- Monitor your utility voltage and current real time for any problems and consult the supplier as soon as any abnormality occurs.
- Special electrical equipment is needed to pinpoint this type of power problem. Taking voltage and current measurements do not tell the whole story. Even looking at the waveforms with an oscilloscope may not be good enough. Each harmonic in the voltage and current waveforms must be quantified.
- Running all lift equipment and snowmaking together in the fall is a good test of the power system, lift communication and equipment reliability.

Reference and Credits

“IEEE Recommended Practices and Requirements for Harmonic Control in Electrical Power Systems”, IEEE Std. 519-1992, page 78 Table 10.3 “Current Distortion Limits for General Distribution Systems”, page 85 Table 11.1 “Voltage Distortion Limits”, IEEE, New York, NY, April 12, 1993

Events and Fluke 41B documented by Vaughn DeCrausaz of Starboard Electric.

Fluke RPM graphs by William C. McConnell,III, Var+Technologies, wcm@vartechnologies.com

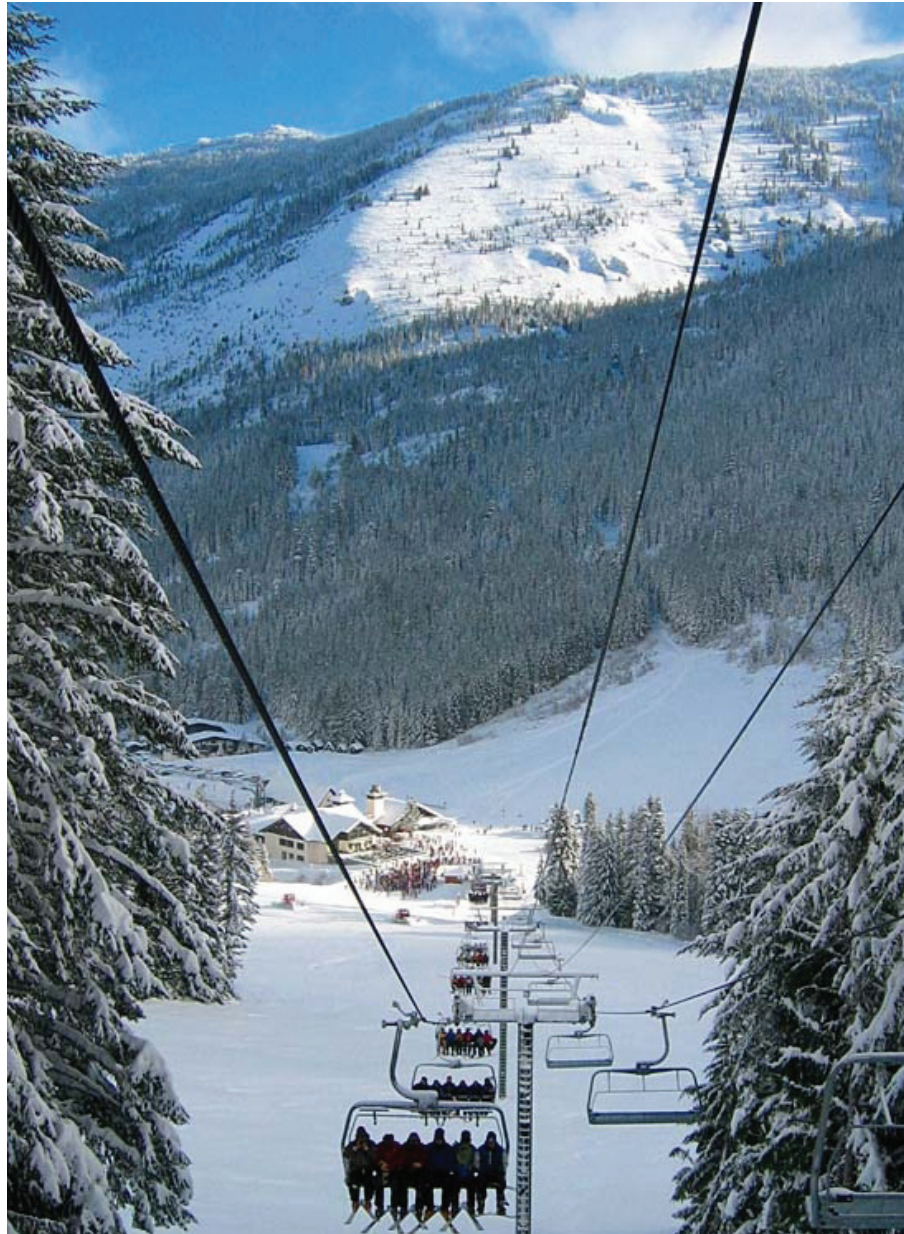

Photo by Don Sveta

Fluke. Keeping your world up and running.®

Fluke Corporation
PO Box 9090, Everett, WA USA 98206

Fluke Europe B.V.
PO Box 1186, 5602 BD
Eindhoven, The Netherlands

For more information call:
In the U.S.A. (800) 443-5853 or
Fax (425) 446-5116
In Europe/M-East/Africa +31 (0) 40 2675 200 or
Fax +31 (0) 40 2675 222
In Canada (800)-36-FLUKE or
Fax (905) 890-6866
From other countries +1 (425) 446-5500 or
Fax +1 (425) 446-5116
Web access: <http://www.fluke.com>

©2006-2007 Fluke Corporation. All rights reserved.
Specifications subject to change without notice.
Printed in U.S.A. 3/2007 2584575 AW-EN-N Rev B