

DTX M12 Channel Adapters

M12 Interface Adapter for DTX CableAnalyzer™ Series

For many years, Ethernet has been the dominant networking technology in the IT (Information Technology) domain; however, the application of Ethernet continues to expand in related networking environments such as industrial automation. With today's industrial networks, it is more important than ever to certify and document multiple media types and connectors to ensure a properly executed installation.

The DTX CableAnalyzer™ Series provides the most comprehensive level of testing, certifying full compliance of the installed cabling with the performance levels established in the TIA-568 standard or the ISO standard 11801:2002.

This datasheet describes a tester interface that allows the user to connect a DTX Series tester directly to Ethernet cabling systems that uses the M12 4-position connectors and to certify the performance of those cabling links.



Cabling Certification

There are many levels of testing for cabling systems, from verifying the continuity of the connection to certifying compliance of an installed cabling system with the applicable TIA or ISO standard. The certification offers the advantage that it represents an assurance or guarantee that the cabling provides the desired bandwidth and transmission capabilities required for the operation of the network. In other words, you know that the cabling system meets the transmission requirements to reliably support the signaling and communication of the network devices. This assurance, in advance of installing the network devices and turning up the service, can save numerous labor hours and headaches during the initial troubleshooting and ongoing maintenance of the network. And its value increases with the mission-critical nature of the network.

Fluke Networks has offered cabling certification test tools since 1993. The DTX CableAnalyzer™ Series represents the most recent and comprehensive certification test tools.

Besides the certification of twisted pair balanced cabling, the DTX Series testers offer accessories or plug-in modules to test coaxial cabling and certify fiber optic cabling. The DTX Series testers offer unique troubleshooting and diagnostics to identify and locate the defect in a failing cabling link.



The M12 Channel Adapter Advantage

The DTX-CHA021S is a set of two M12 channel adapters for use with the DTX-1800. These adapters allow you to test and certify installed channel links to the IEE 802.3 specifications for Fast Ethernet (100BASE-TX).

When used together, the DTX M12 Channel Adapters and DTX-1800 CableAnalyzer™ Series provide the only solution that is fully compliant with industry standards. Now you can accurately certify twisted-pair cabling installations on your factory floor with the DTX CableAnalyzer™ Series and its many accessories and plug-in modules. The M12 interface connector set (DTX-CHA021S) allows you to certify and troubleshoot cabling using the M12 connectors.

The M12 connectors support the transmission requirements for TIA Cat 5e (TIA-568-B.1

(continued)

Clause 11.2). A cabling link that passes the TIA Cat 5e or ISO Class-D requirements fully supports the deployment of Fast Ethernet (100BASE-TX) or 1 Gigabit per second Ethernet (1000BASE-T) over a distance up to 100 m (328 ft). The M12 channels adapters also allow you to test and certify installed channel links to the IEEE 802.3.

General Specifications

Weight, each adapter	51 g (0.11 lb)
Dimensions, each adapter	5.6 x 5.7 x 3.0 cm (2.2 x 2.2 x 1.2 in)
Connector type	M12 -4, "D" coded (IEC 61076-2-101)

The DTX Main and Remote must have version 2.1 or greater for M12 channel adapters performance. Software updates are available at www.flukenetworks.com

Environmental Specifications

Operating temperature	0° to 40° C (32° to 104° F)
Storage temperature	-20° to 60° C (-4° to 140° F)
Safety certification	CE and CSA

M12 Patch Cord Specifications

Cable type	Ethernet cable, Cat5e, shielded, 2 Pair AWG 26 stranded (7 wire), RAL 5021 (water blue), M12 4 pos. D-coded
Number of positions	4
Fixed cable length	2 m
Volume resistance	≤ 5 mΩ
Insulation resistance	≥ 100 MΩ
Ambient temperature	-20° to 50° C (32° to 122° F)
Inflammability class acc to UL 94	V0
Surge voltage category	II
Pollution degree	3
Degree of protection	IP20/IP67
External cable diameter	6.7 mm
Transmission characteristics	Cat 5 (IEC 11801:2002), Cat 5e (TIA 568B:2001)

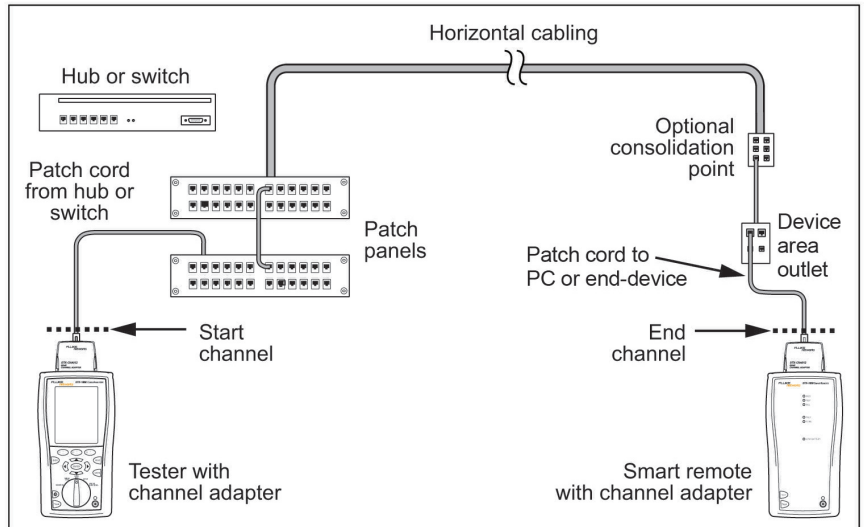

Figure 1: Connecting to a Channel Link

Ordering Information

Model Number	Name	Description
DTX-1800-IE	DTX-1800 CableAnalyzer Industrial Ethernet	Includes DTX-1800 main and smart remote, LinkWare PC software, 128MB MMC card, Cat 6A/class EA permanent link adapters (2), Cat 6/Class E channel adapters (2), headsets for talk (2), AC chargers (2), carrying case, USB interface cable (Mini-B), serial RS232 cable (DB9 to IEEE1394), user manual and M12 channel-adapter kit
DTX-CHA021S	M12 Channel Adapters (set of 2)	M12 channel adapters – set of two M12 -4 "D" coded
DTX-CHA021	M12 Channel Adapter (1)	M12 channel adapter – one adapter M12 -4 "D" coded
M12PC	M12/M12 Patch Cord	Two-meter M12/M12 patch cord

NETWORK SUPERVISION

Fluke Networks
P.O. Box 777, Everett, WA USA 98206-0777

Fluke Networks operates in more than 50 countries worldwide. To find your local office contact details, go to www.flukenetworks.com/contact.

©2008 Fluke Corporation. All rights reserved.
Printed in U.S.A. 9/2008 3369516 D-ENG-N Rev A