

## Vibration analysis goes mainstream

by John Bernet

### Application Note

Using vibration analysis to evaluate machine health has many benefits, and with advances in sensor, recording, and analysis technology, vibration analysis is now within the reach of even small organizations.

- Measuring the vibrations of motors, pumps, and other common machines can reveal valuable information about machine health—or impending failures.
- Vibration analysis can reveal four of the most common mechanical faults: imbalance, misalignment, wear, and looseness.
- Easier measurement procedures combined with automated vibration analysis enables personnel with minimal training and experience to use vibration to evaluate machine health and determine required maintenance.

Most machines have rotating parts, and rotating parts vibrate. Measuring how and how much those parts vibrate can tell you a lot about the health of a machine. Whether it's the rumble of worn bearings or the shaking, shimmying, or thumping of loose, misaligned, or unbalanced parts, machines have a tale to tell to those who are willing and able to listen.

Vibration analysis—the art and science of measuring and interpreting those telltale rumbles and shakes—has been around for decades, but mostly in the domain of specialists operating exotic instruments for corporations and government agencies with mission-critical equipment and very deep pockets. For everyone else, “vibration analysis” was typically performed by a mechanic using a makeshift stethoscope fashioned from a screwdriver—the tip held to the machine, the handle held to the ear—or, more often, not done at all. Recent developments in vibration sensor, data acquisition, and analysis technologies,

however, are making vibration analysis cheaper, easier, and more widely available.

#### What can vibration analysis tell you?

Among the most important mechanical faults that vibration analysis can reveal are the following:

- **Imbalance** – A “heavy spot” in a rotating component causes vibration when the unbalanced weight rotates around the machine’s axis, creating a centrifugal force. As machine speed increases the effects of imbalance become greater. Imbalance can severely reduce bearing life as well as cause undue machine vibration.
- **Misalignment/shaft runout** – Vibration can result when machine shafts are out of line. Angular misalignment occurs when the axes of (for example) a motor and pump are not parallel. When the axes are parallel but not exactly aligned, the condition is known as parallel



misalignment. Misalignment may happen during assembly or develop over time, due to thermal expansion, components shifting, or improper reassembly after maintenance. The resulting vibrations may be in the direction of the rotation, along the shaft axis, or both.

- **Wear** – As components such as bearings, drive belts, or gears become worn, they may cause vibration. When a roller bearing race becomes pitted, for instance, the bearing rollers will cause a vibration each time they travel over the damaged area. A gear tooth that is heavily chipped or worn, or a drive belt that is breaking down, can also produce vibration.
- **Looseness** – Vibration that might otherwise go unnoticed may become obvious and destructive if the component that is vibrating has loose bearings or is loosely attached to its mounts. Such looseness may or may not be caused by the underlying vibration. Whatever its cause, looseness can allow any vibration present to cause damage, such as further bearing wear, or wear and fatigue in equipment mounts and other components.

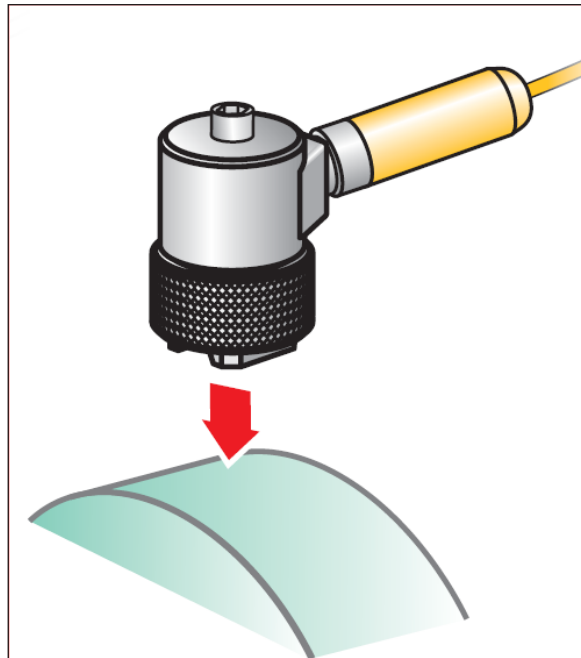

Figure 1. Attaching a vibration sensor with a magnetic mount.

### How do you measure vibration?

Vibration sensors have advanced far beyond the mechanic's screwdriver. There are a variety of sensor types, but the accelerometer is the most common. To take a measurement, a small metal sensor is attached to the appropriate location on the equipment to be tested. The attachment, which can be permanent for continuous monitoring or temporary for machines that are evaluated only periodically, must be at a position on the machine that reveals the best information about the vibration that is being investigated (at the bearings of a motor, for example, or close to a rotating shaft).

Inside the sensor, an array of tiny electronic accelerometers convert movement along any of the three axes (up and down, back and forth, side to side) into an electrical signal that is fed to a recording device. Recorded vibration data can be analyzed at the test site for an immediate diagnosis, and can also be saved for later analysis or comparison with earlier recordings to monitor trends in machine health.

Studies conducted by the US Navy<sup>1</sup> found that many vibration analysis programs were not collecting all of the data that was needed to make an accurate diagnosis. The studies concluded that to diagnose machine condition accurately, data was needed from all three axes of a rotating shaft. When only two axes of data were used, diagnostic accuracy dropped to 80 %. When data from only a single axis was analyzed, diagnosis accuracy dropped to 46 %.

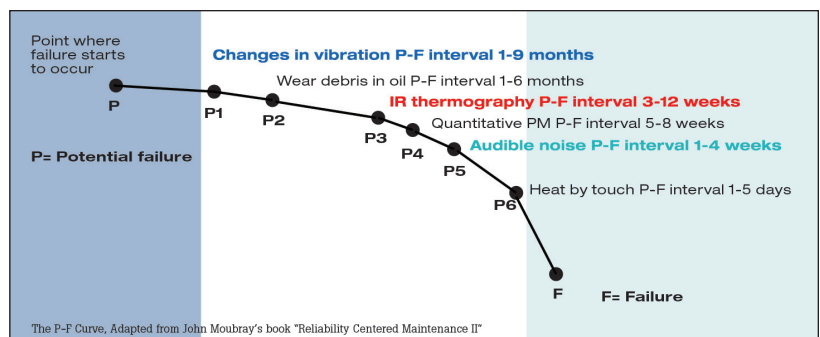

Figure 2. Potential failure curve over a nine month interval.

## Automating the analyst

Collecting and storing vibration data from a sensor is only the beginning. To be useful, vibration data must be analyzed and interpreted. A vibration graph can reveal a lot to a trained and experienced vibration analyst, but hiring (or training and then retaining) a vibration analyst is such an expensive proposition that only large, well-funded organizations have been able to afford to keep analysts on staff. Everyone else has had to hire vibration consultants only when need justified and budget allowed.

Making vibration analysis available and affordable for everyone who could benefit from it would require not just affordable equipment but also “automating the analyst”; automated diagnostic programs were needed that could analyze raw vibration data and give useful, simple, “actionable” recommendations for non-experts. The key to automating vibration analysis, as it turned out, was to compare the vibration data in question with data from a similar, “healthy,” “known good” machine. Although the concept of comparing the data from the machine in question with “baseline” data from a similar, known-good machine is simple, the implementation is complicated. A vibration analysis program performs a sophisticated analysis, comparing hundreds of data points with the “fault patterns” of similar machines to give a simple, understandable, diagnosis that makes clear how healthy the machine is and whether maintenance is needed. The resulting diagnostic report should give the operator or maintenance technician a clear picture of machine condition and action required.

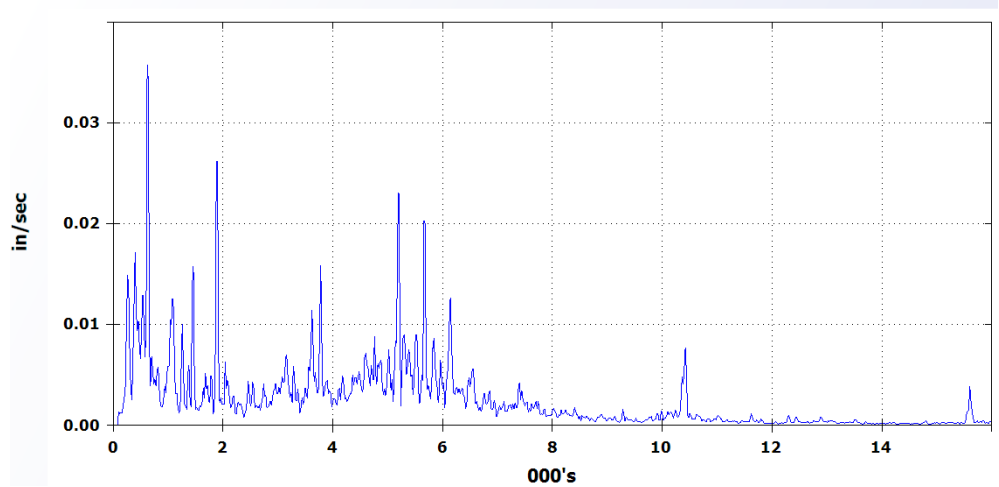

Figure 3. Vibration intensity and frequency of a rotating shaft.

## What are the benefits of vibration analysis?

**Predictability.** Studies have shown (Figure 2) that vibration analysis can provide early warnings of impending machine failure, giving maintenance staff time to schedule required repairs and acquire needed parts.

**Safety.** Having information about machine health enables operators to take faulty equipment offline before a hazardous condition occurs.

**Revenue.** Well-maintained machines have fewer unexpected and serious failures, helping to prevent production stoppages that cut into the bottom line.

**Increased maintenance intervals.** When machine health is being tracked, maintenance can be scheduled by need, not just by accumulated hours of operation.

**Reliability.** Monitored machinery has fewer unexpected or catastrophic failures.

**Cost savings.** Running machinery until failure often results in more expensive repairs, overtime, and forced purchases. 25 years of documented savings show a 20:1 benefit-to-cost ratio for vibration analysis programs.<sup>2</sup>

**Peace of mind.** A better understanding of machine health builds confidence in maintenance schedules, budgeting, and productivity estimates.

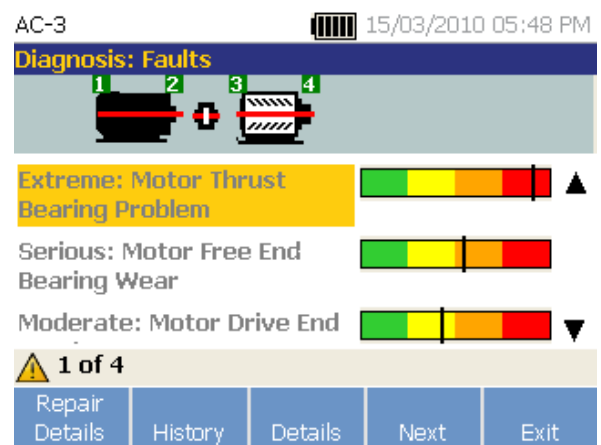

Figure 4. Automated vibration analysis can report on machine health in terms that are understandable and actionable by technicians without vibration analysis experience.

## Why add vibration analysis to a maintenance program?

“Run to fail” maintenance programs, while simple, often have costlier repairs, loss of revenue from production stoppage, and expensive overtime. Preventive maintenance programs, in which machinery is serviced after a certain number of hours of operation, can result in unnecessary work being performed, and unmonitored machinery can still fail before the maintenance interval elapses. When vibration analysis is incorporated into a maintenance program, however, the condition of



monitored machines is known, so unnecessary maintenance work is avoided and required work can be scheduled for convenient times and when parts are available. Maintenance staff knows which machines are good enough to run, which need repairs scheduled soon, and which need to be shut down before they fail.

**How to get started with a vibration analysis program**

The US Navy determined 30 years ago that it wanted the benefits of vibration analysis, but could not afford to have a vibration expert on every ship. What are the roadblocks to implementing a program?

- Training staff, and then retaining staff with the extensive vibration analysis skills, is expensive.
- Results achieved may not justify the cost in equipment, training, labor, etc.
- Company priorities change so a vibration program is scrapped.

Recent advances in vibration analysis, however, have enabled programs that can diagnose common machine faults without the need for prohibitively expensive equipment and expert operators.

The suggestions below can help any organization in its efforts to implement a vibration analysis program.

- Start small and grow. Don't try to monitor 500 machines in a plant all at once. Instead, choose 25 to 50 machines to start with, then add additional machines as priorities, time, and budget allow. Organizations that already have a reliability group can increase the scope of their maintenance program to include vibration analysis.
- Focus on problem machines. If you have machines that have a history of failure or a few machines that can take down half the plant, start with them. Even small machines that aren't deemed big enough for a reliability group to monitor may be important to the maintenance and operations groups because they are the ones that require the most attention.
- Focus on the common machine faults—imbalance, misalignment, looseness, and bearing failures—because they account for 80-90 percent of machine faults.
- Use automation and proven measurement methodology to get a complete picture of the machine's entire power train. Maintenance technicians and operators don't have time to look over reams of data—they have a plant to run. A system that screens the data and provides answers about what is wrong with a machine and what to do to fix it should be the goal.

**Summary**

Advances in vibration sensor, data acquisition, and analysis technologies have enabled the introduction of powerful, portable, affordable, easy-to-use vibration measurement and analysis tools that enable even smaller organizations with limited training and hardware budgets to enjoy the considerable benefits of vibration analysis.

**About the Author**

John Bernet is a vibration application specialist at Fluke Corporation and a Category II-certified Vibration Analyst. He has over 20 years of vibration analysis experience in industry and the US Navy. John can be reached at John.Bernet@fluke.com.

**References**

- <sup>1</sup> **Triaxial Vibration Spectral Data: An Important Ingredient for Proper Machine Diagnostics**, William Watts, P.E., 2009, Azima DLI ([www.azimadli.com](http://www.azimadli.com))
- <sup>2</sup> **Benefit to Cost Analysis of the Machine Condition Analysis (MCA) Program on U.S. Aircraft Carriers**, Loren Cleven, P.E., Azima DLI ([www.azimadli.com](http://www.azimadli.com))



**Figure 5.** Technician using a handheld vibration analyzer.

**Fluke.** *Keeping your world up and running.®*

**Fluke Corporation**  
PO Box 9090, Everett, WA 98206 U.S.A.

**Fluke Europe B.V.**  
PO Box 1186, 5602 BD  
Eindhoven, The Netherlands

**For more information call:**  
In the U.S.A. (800) 443-5853 or  
Fax (425) 446-5116  
In Europe/M-East/Africa +31 (0) 40 2675 200 or  
Fax +31 (0) 40 2675 222  
In Canada (800)-36-FLUKE or  
Fax (905) 890-6866  
From other countries +1 (425) 446-5500 or  
Fax +1 (425) 446-5116  
Web access: <http://www.fluke.com>

©2011 Fluke Corporation.  
Specifications subject to change without notice.  
Printed in U.S.A. 9/2011 4100700A A-EN-N

**Modification of this document is not permitted without written permission from Fluke Corporation.**