

How hot? Use the spot.

Application Note

Temperature is the second most common measurement in the world (the first is time). For something that is measured so often, wouldn't it be great to have a thermometer that's as easy to carry and as fast to read as your wristwatch?

Fluke's family of infrared (IR) thermometers gives you speed and convenience. Point. Squeeze. Read the results. It's quick and easy, and helps you get your job done faster.

In addition, Fluke's newest infrared thermometer adds another element—improved targeting for increased accuracy. The Fluke 62 MAX+ provides two targeting lasers to help you better see "the spot." To better understand how the 62 MAX+ will help you, let's take a look at what the spot means.

For anyone who uses an IR thermometer, understanding the measurement spot is key to getting accurate measurements. Think about using the spot in the same way you see things with your eyes. If you're up close to an object, you can see only the things directly in front of you. As you move farther back, your field of view expands and you see a much wider perspective.

The formal name for this is "distance to spot ratio." If your thermometer has a 10:1 distance to spot ratio, and you are 10 inches away from your target, you will measure the temperature of a one-inch circle. If you are 10 feet away, your measurement spot will be a one-foot circle.



Figure 1 shows an example of why this is important. In the illustration, a hot pipe is mounted on a brick wall. On the left side of the illustration, a user takes a measurement from a distance where the spot covers not only the hot pipe, but also the cooler brick wall. The reading shows the average of the entire spot. On the right side, the user has moved closer and the spot is smaller. The thermometer gives an accurate reading of the temperature of the hot pipe.

The most common IR thermometers use a single laser in the center of the spot. If you can do the mental math to estimate the measurement spot, great. But the Fluke 62 MAX+ offers a different approach, using dual, rotating lasers to show the outside of the circle that defines

the measurement spot. In other words, with the 62 MAX+, the spot is between the dots.

Figure 2 shows the same example of a hot pipe mounted on a brick wall, but using the 62 MAX+ with dual, rotating lasers. With dual lasers, it becomes easy for the user to visualize the size of the circle that is being measured. The results are the same, but it is easier for the user to see and measure exactly what was intended.

Laser-targeted infrared thermometers are great tools for making fast temperature measurements. To improve accuracy, users should understand the size of the measurement spot. And to really stay ahead of the game, use an IR thermometer with dual lasers that define the outer edges of the spot.

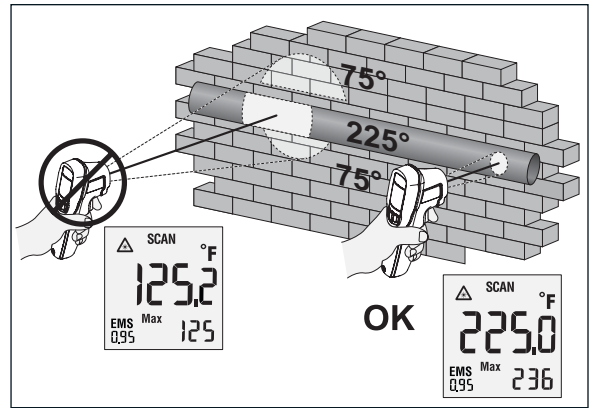

Figure 1

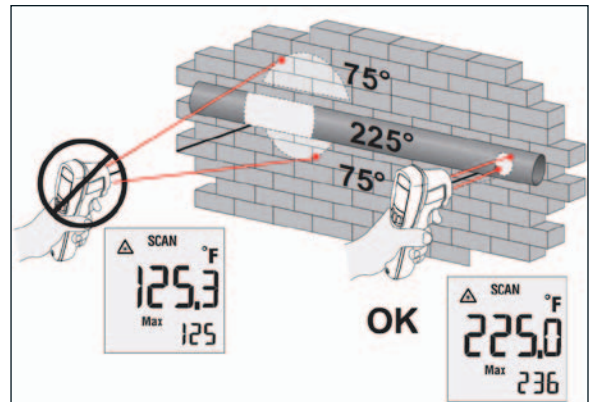

Figure 2

Fluke. *Keeping your world up and running.*®

Fluke Corporation

PO Box 9090, Everett, WA 98206 U.S.A.

Fluke Europe B.V.

PO Box 1186, 5602 BD Eindhoven, The Netherlands

For more information call:

In the U.S.A. (800) 443-5853 or Fax (425) 446-5116
 In Europe/M-East/Africa +31 (0) 40 2675 200 or Fax +31 (0) 40 2675 222
 In Canada (800)-36-FLUKE or Fax (905) 890-6866
 From other countries +1 (425) 446-5500 or Fax +1 (425) 446-5116
 Web access: <http://www.fluke.com>

©2012 Fluke Corporation.
 Specifications subject to change without notice.
 Printed in U.S.A. 5/2012 4221738A_EN

Modification of this document is not permitted without written permission from Fluke Corporation.